

The image features a yellow background on the left side, transitioning into a white background with a light gray grid pattern on the right. Several large, stylized arrows in shades of blue, red, and gray point from the left towards the right, following a curved path. The arrows vary in size and color, creating a sense of movement and direction.

Non-Discrimination under International Tax Law

Harshal Bhuta

**M.Com., F.C.A., A.D.I.T., LL.M. (Hons.) in International
Tax Law [Wirtschaftsuniversität Wien]**



Non-Discrimination under ITL

Introduction:

- Prof. Kees Van Raad - An incoherent collection of fairly narrow clauses
- Art. 24 deals only with direct and specific cases of non-discrimination although one may infer that it is very wide in its application due to its overriding nature over the scope of the DTAA
- Contextual application – Art. 24 does not override other articles of the DTAA (eg: Article 7(3) of certain DTAA – subject to limitation of taxation laws of the source state)
- Preferential treatment is not prohibited (Reverse discrimination)
- MFN treatment not reqd (cf. India-Spain DTAA Protocol)



Non-Discrimination under ITL

Introduction:

- No justification required for establishing discrimination
 - ND provisions have absolute character [M. No. 4 - Klaus Vogel]
 - Differentiation vs. discrimination [Daimler Chrysler India (P.) Ltd. [2009] 29 SOT 202 (PUNE)]. Reliance on Prof. Kees Van Raad book may be misplaced. There should be no need to establish ground for differentiation in treatment that it is unreasonable, arbitrary or irrelevant.
 - Grounds of justification prevalent under EU law: written grounds for justification, overriding reasons in public interest and proportionality test
 - Article 14 of Indian Constitution: Reasonable discrimination

Non-Discrimination under ITL

OECD / UN MC :

24(1)

- Nationality based ND

24(2)

- Stateless persons ND

24(3)

- PE ND

24(4)

- Debtor – Creditor ND

24(5)

- Ownership based ND



Non-Discrimination under ITL

Article 24(1) – OECD / UN MC:

Nationals of a Contracting State shall not be subjected in the other Contracting State to **any taxation** or **any requirement connected therewith**, which is **other** or **more burdensome** than the taxation and connected requirements to which nationals of that other State in the same circumstances, in particular with respect to residence, are or may be subjected. This provision shall, notwithstanding the provisions of Article 1, also apply to persons who are not residents of one or both of the Contracting States.

Non-Discrimination under ITL

Article 24(1) – OECD / UN MC:

- Historical background: to strengthen diplomatic protection to nationals wherever resident
- Definition of “national”:
 - Covers individuals and companies (OECD/UN MC Commentary)
 - Some DTAAAs define specifically whereas some do not; France reservation that it would apply only to individuals
 - Companies and corporate bodies cannot be considered as nationals [Credit Llyonnais [2005] 94 ITD 401]; PE ND clause would become redundant otherwise [1998] 100 TAXMAN 206 (AAR - N. DELHI)]
- Condition of reciprocity: Only in commentary (Para 5) but not in bare provisions. Equal commitment from both states [Article 60(1) VLCT]

Non-Discrimination under ITL

Article 24(1) – OECD / UN MC:

- Meaning of “same circumstances”: Substantially similar circumstances both in law and in fact
- Criteria for same circumstances: Residence and other relevant criteria which is the basis for tax differentiation
- Therefore circumstances should be the same and only nationality should differ in order to test discrimination under Art. 24(1)
- US Model Technical explanation as well as India-US DTAA Technical explanation: Comprehensive taxation not comparable with Limited liability taxation. Therefore US is not obliged to grant same taxing regime to Indian national (being non-US resident) vis-à-vis US national (being non-US resident) for US source income.

Non-Discrimination under ITL

Article 24(1) – OECD / UN MC:

- “Taxation”: Basis of charge, computation & rate
- “Other requirement connected therewith”: Returns, payment of tax (including advance tax, TDS), prescribed forms, prescribed periods, etc
- “Other”: Taxation as well as other requirements connected therewith cannot deviate from those applicable to nationals even though they may not be burdensome for non-nationals
- “More burdensome”: Must not be more onerous
- Even though Art. 24(1) prohibits taxation or connected requirements which are different than those applicable to nationals, preferential treatment can be granted to non-nationals without violating Art. 24(1) – By virtue of Para 3 and 14 to Art 24 OECD MC Commentary [M. No. 32 Klaus Vogel]

Non-Discrimination under ITL

Example of “same circumstances” for individuals

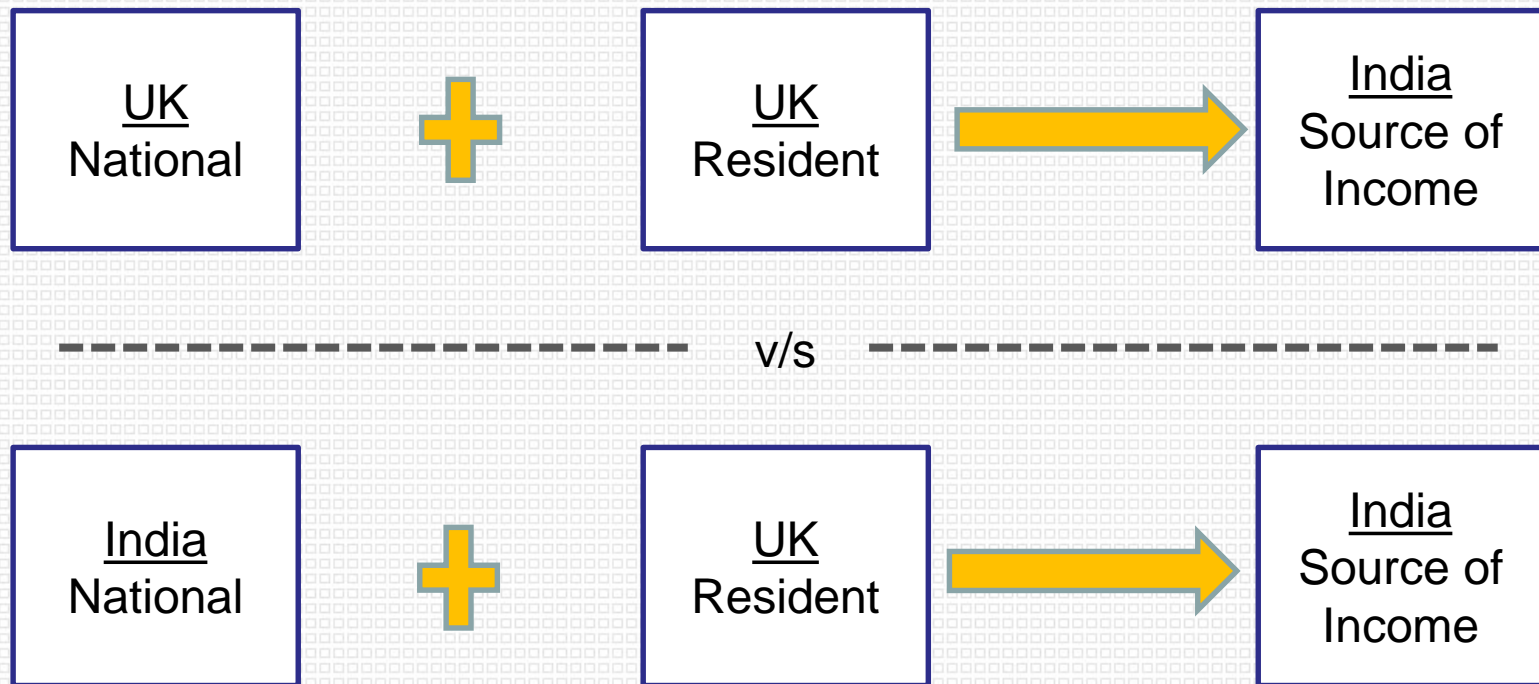

Non-Discrimination under ITL

Example of “same circumstances” for individuals

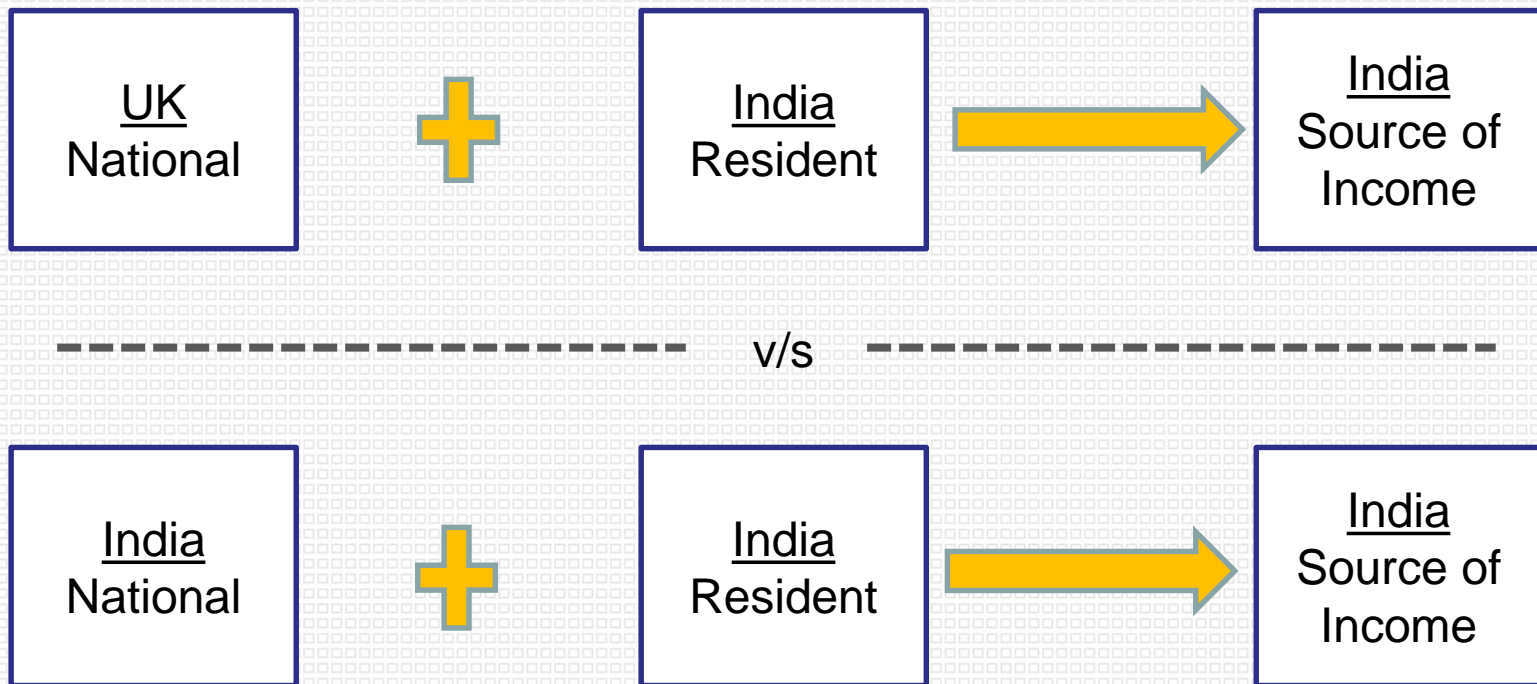

Non-Discrimination under ITL

Example of “same circumstances” for individuals



v/s

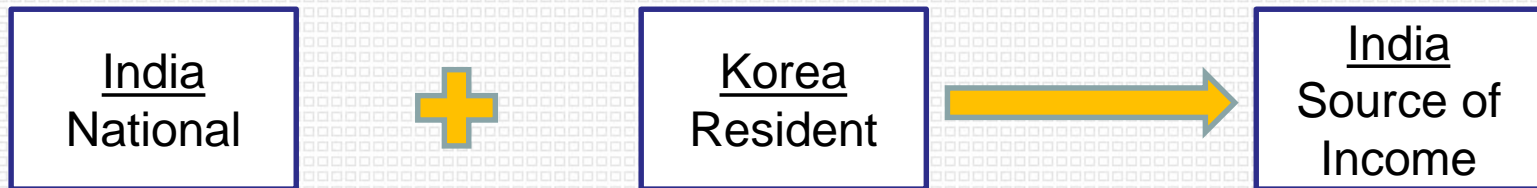

v/s



Non-Discrimination under ITL

Example of “same circumstances” for individuals:

- Same residence does not restrict the scope of Art. 24(1). In the above example, resident of Korea can also access Japan-India DTAA.
- In the comparison, the non-resident of India (viz. in law) has to be a resident of Korea (viz. in fact). Factual similarity required in order to discourage use of tax havens (Para 8 of Commentary on Art. 24(1)). For e.g. State S restricts WHT to 10% only if ETR in State R >15%. Suppose State R₁ ETR = 5% & State R₂ ETR is 20%. In this case, State R₂ National cum State R₁ Resident can be compared only with State S National cum State R₁ Resident to avail ND protection under R₂ – S DTAA.



Non-Discrimination under ITL

Example of “same circumstances” for **companies**:

- Even for companies, discrimination based on nationality (registration/incorporation) is prohibited. (Example 1)
- In many cases, incorporation may be the sole criteria for ascertaining ‘nationality’ as well as ‘residence’ for company under domestic regulations. In such cases, Art. 24(1) may become redundant. (Example 2)

Non-Discrimination under ITL

Example 1

➔ Residence Criteria

➔ Company X
(tie breaker test based on POEM)

State A

Incorporation or
POEM

POEM
↓
(Resident)

State B

Incorporation

Incorporated
↓
(National)

State A (Domestic Law)

Company Incorporated in State A $\xrightarrow{\text{Dividend}}$ Company Incorporated in State A

Tax exempt for recipient

Article 24(1) application ✓

Company Incorporated in State A $\xrightarrow{\text{Dividend}}$ Company X

Therefore, Tax exempt for Co. X

Non-Discrimination under ITL

Example 2

➔ Residence Criteria

➔ Company X
(tie breaker test based on incorporation)

State A

Incorporation

--

State B

Incorporation

Incorporated
➔ (Resident & National)

State A (Domestic Law)

Company Incorporated in State A $\xrightarrow{\text{Dividend}}$ Company Incorporated in State A

Tax exempt for recipient

Article 24(1) application 

Company Incorporated in State A $\xrightarrow{\text{Dividend}}$ Company X

Cannot be Tax exempt for Co. X

Non-Discrimination under ITL

Relevant Indian judicial decisions under Article 24(1) – OECD / UN MC:

- Higher tax rate applicable to foreign companies: Chohung Bank [[2006] 102 ITD 45 (MUM)] and host of other decisions. DTAA does not override Finance Act. Contrast with decision which have held that DTAA rate includes surcharge and EC.
- ‘Same circumstances’:
 - Chohung Bank [[2006] 102 ITD 45 (MUM)]. Foreign banking company not comparable to Indian banking company. Are all those differentiations relevant for consideration per se under Art. 24(1) since tax rate not dependent upon such differentiations?
 - Same conditions not satisfied by foreign national, hence deduction under Sec. 80M not granted. [BNP Paribas SA [57 SOT 82]]

Non-Discrimination under ITL

Relevant Indian judicial decisions under Article 24(1) – OECD / UN MC:

- Sec. 48 2nd Proviso: No discrimination based upon nationality but distinction based on residence. [Transworld Garnet Co. Ltd [2011] 333 ITR 1 (AAR)]
- Sec. 92B: Distinction based on residential status and not nationality [Canoro Resources 313 ITR 2 (AAR)]
- Sec 47(vi): If a case of amalgamation results in some special benefits to a local company and its shareholders, there is no reason to deny the same to a foreign company and its shareholders in similar case of amalgamation [Banca Sella S.p.A. [2016] 72 taxmann.com 360 (AAR - New Delhi)].
Whether correct reading?

Non-Discrimination under ITL

Relevant Indian judicial decisions under Article 24(1) – OECD / UN MC:

- Sec. 201: Same period of limitation is required to be applied equally for all payees whether resident or non-resident [Google India (P.) Ltd. [2017] 190 TTJ 409 (Bengaluru – Trib.)]. Whether correct interpretation of Art. 24?
- Beneficial view to be extended to NR in case of two views: Where two views are available on an issue one favourable to the assessee and the one against the assessee, the view which is favourable to the assessee and does not support levy of tax on the assessee should be preferred, should be applied to non-resident assessee. [Solid Works Corpn. [2012] 18 taxmann.com 189]. Incorrect decision? Where is allegation of discrimination based on nationality?



Non-Discrimination under ITL

Article 24(2) – OECD / UN MC:

Stateless persons who are residents of a Contracting State shall not be subjected in either Contracting State to any taxation or any requirement connected therewith, which is other or more burdensome than the taxation and connected requirements to which nationals of the State concerned in the same circumstances, in particular with respect to residence, are or may be subjected.

- Not present in most of Indian DTAA's



Non-Discrimination under ITL

Article 24(3) – OECD / UN MC:

The **taxation** on a **permanent establishment** which an enterprise of a Contracting State has in the other Contracting State **shall not be less favourably levied** in that other State than the taxation levied on enterprises of that other State **carrying on the same activities**. This provision shall not be construed as obliging a Contracting State to grant to residents of the other Contracting State any personal allowances, reliefs and reductions for taxation purposes on account of civil status or family responsibilities which it grants to its own residents.

Non-Discrimination under ITL

Article 24(3) – OECD / UN MC:

- “Taxation”: Other requirements not covered.
- “Shall not be less favourably levied”: The result solely counts. If tax levy (in monetary terms) is more burdensome, then covered under Art. 24(3). Otherwise, differential requirements that may be prescribed for PEs may be permitted.
- “Same activities”:
 - Same sector of activities.
 - Same type of business (John Avery Jones).
 - Similar legal structure [Mashreqbank PSC [2007] 14 SOT 1 (MUM.)]
 - Regulated vs. unregulated activities



Non-Discrimination under ITL

Article 24(3) – OECD / UN MC:

- Consequence of application of Art. 24(3) - Equal treatment to PE for:
 - Deductions for expenses
 - Depreciation and provision for reserves
 - Loss c/f
 - CG computation
 - Tax incentives (See India position on commentary)
(Consequence of decisions on Sec. 80HHE & 80HHC)
- Group taxation benefit not within scope of Art. 24(3)
- Transfer pricing not in conflict with this provision

Non-Discrimination under ITL

Participation exemption for holdings owned by PE

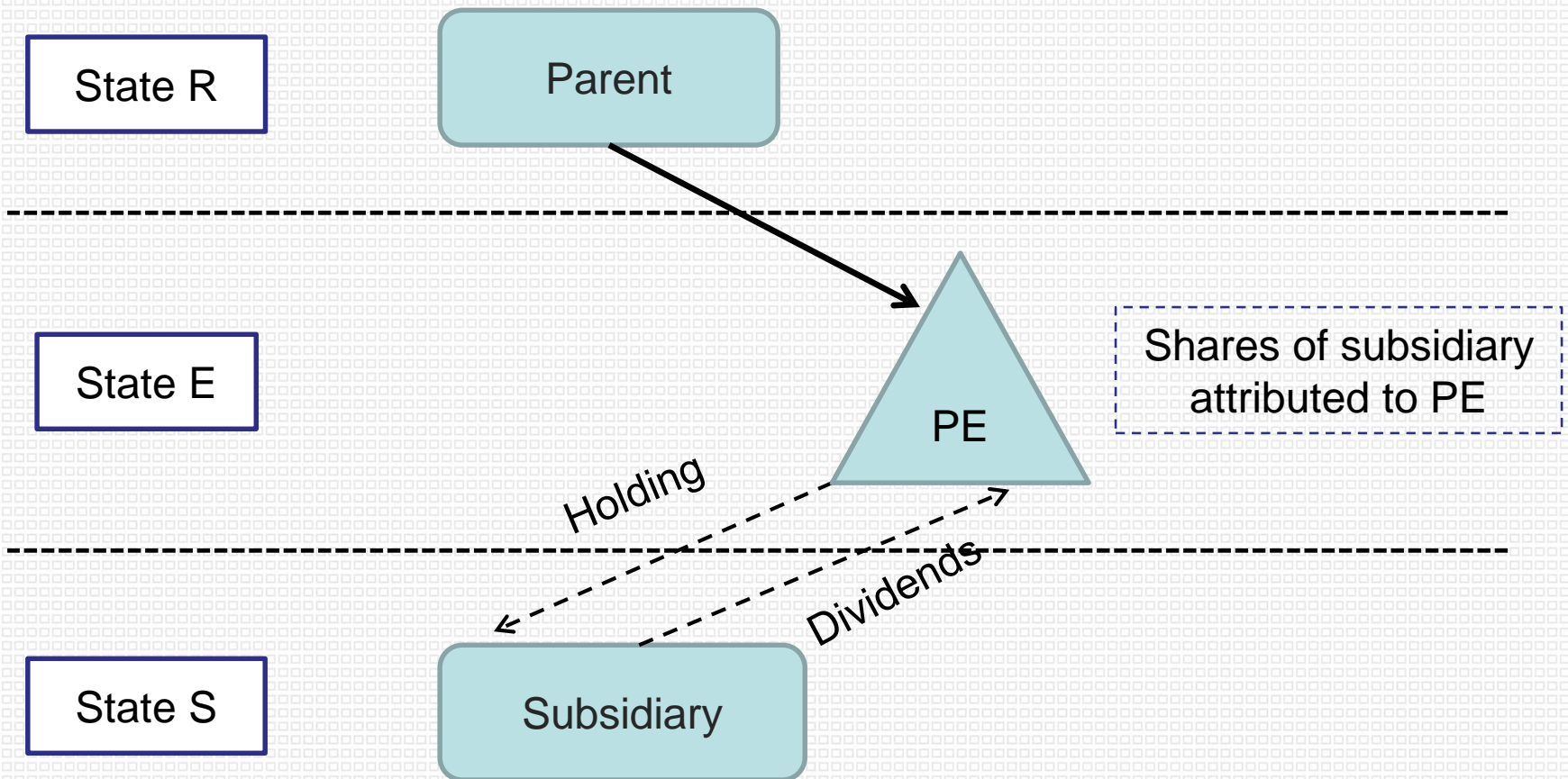



Non-Discrimination under ITL

Participation exemption for holdings owned by PE

- Arguments for extension:
 - Once profits are taxed at subsidiary level, they shouldn't be taxed once again
 - State R cannot be expected to exempt PE profits as well as grant underlying tax credit for taxes on profits of subsidiary
- Arguments against extension:
 - Avoiding double taxation is responsibility of State R and not that of State E



Non-Discrimination under ITL

Article 24(3) – OECD / UN MC:

- Progressive taxation
 - Profits of the whole company to be considered for determining slab rate applicable to PE profits
 - Losses to be ignored
 - Principle of equity?
- Compatibility of Branch Profits tax and Branch level interest tax
- WHT in case of payment by State E payer to PE located in State E: No discrimination if WHT applicable to payments to residents too (Para 64-65 to Art. 24(3) OECD MC Commentary). But is WHT a final tax?

Non-Discrimination under ITL

Triangular Situation

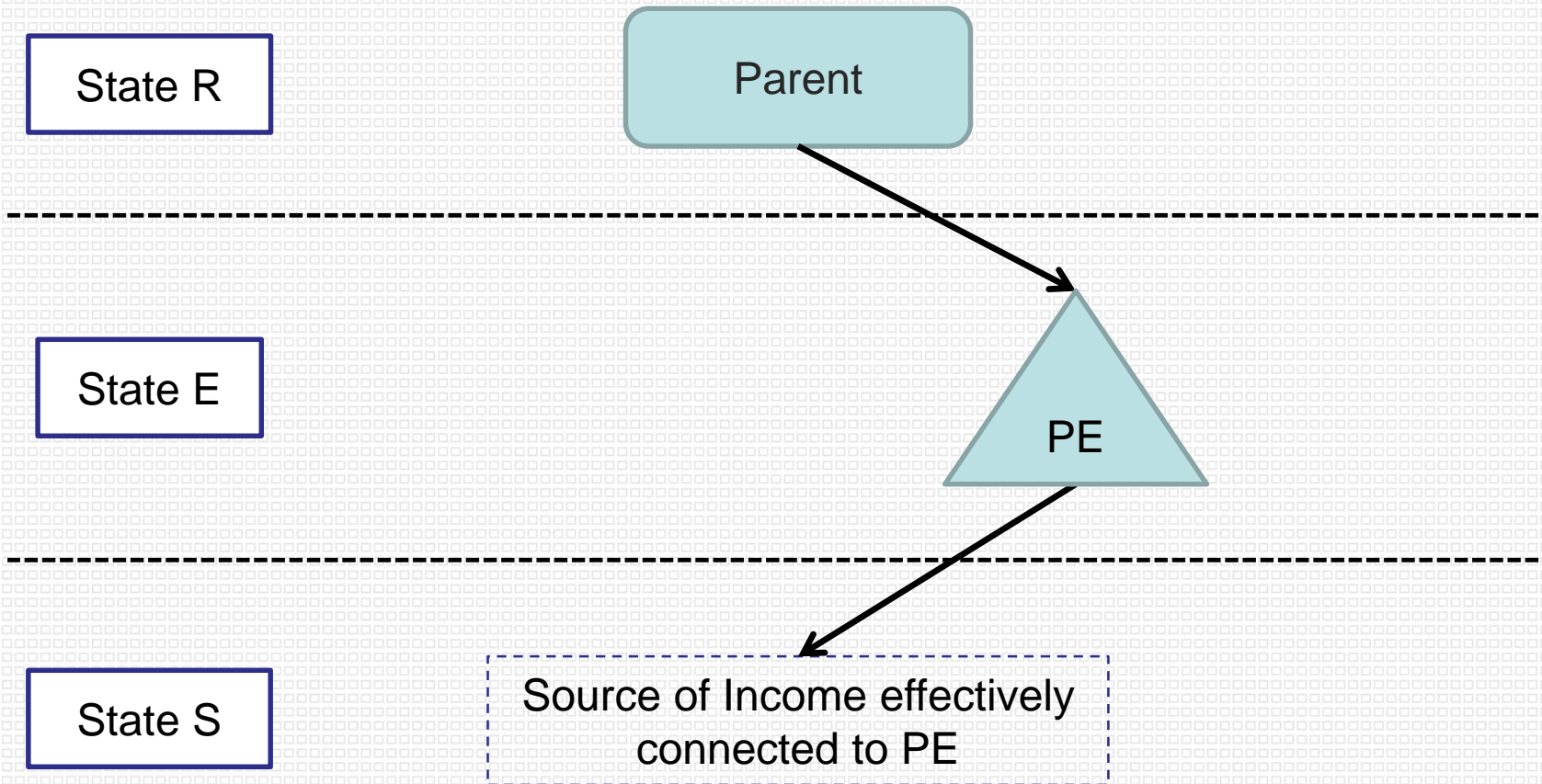

Non-Discrimination under ITL

Triangular situation:

- Three scenarios:
 - Domestic tax law of State E provides for tax credit to be granted to residents as well as PE of a non-resident: No need for application of ND provision
 - Domestic tax law of State E provides for tax credit to be granted to residents but not to PE of a non-resident: Application of ND provision and therefore credit granted to PE by State E
 - Tax Credit is allowed to residents only under DTAA entered by State E with 3rd State: Can benefit of Art. 25 of E-S DTAA be applied to PE by virtue of ND provision under R-E DTAA? Only if such specific provision is contained under R-E DTAA to grant credit to PE of State S taxes for lower of taxes deducted as per R-S DTAA or creditable as per E-S DTAA.

Non-Discrimination under ITL

Relevant Indian judicial decisions under Article 24(3) – OECD / UN MC:

- 80HHC:
 - Allowed since carrying on same activities [Bhagwan Shivilani (53 SOT 233)].
 - 80HHC considered deduction and hence denied [Mustaq Ahmed (126 TTJ 523)]. Didn't not accept contention of 'personal' qualification. [Contrast with Banca Sella S.p.A.]
- 80HHE: Allowed [Rajeev Gajwani (129 ITD 145)(Ahd SB)]
- 44C: Art. 24(3) takes precedence over Art. 7(3) and therefore 44C not applicable [Metchem Canada Inc. vs DCIT (2006) 99 TTJ 702 (ITAT Mumbai)]. Some treaties have exception for Art. 7(3) cases under Art. 24(3) provision itself but in any case, Art. 24(3) has to be read in context of Art. 7(3) and most Indian DTAA's have wording under Art. 7(3) that subject it to limitations under domestic tax law for deductions (eg. 44C)



Non-Discrimination under ITL

Article 24(4) – OECD / UN MC:

Except where the provisions of paragraph 1 of Article 9, paragraph 6 of Article 11, or paragraph 4 of Article 12, apply, interest, royalties and other disbursements paid by an enterprise of a Contracting State to a resident of the other Contracting State shall, for the purpose of determining the taxable profits of such enterprise, be deductible under the same conditions as if they had been paid to a resident of the first-mentioned State. Similarly, any debts of an enterprise of a Contracting State to a resident of the other Contracting State shall, for the purpose of determining the taxable capital of such enterprise, be deductible under the same conditions as if they had been contracted to a resident of the first-mentioned State.

- This provision does not apply to mispricing.
- In general, it applies even to trade payments

Non-Discrimination under ITL

Relevant Indian judicial decisions under Article 24(4) – OECD / UN MC:

- 40(a)(i):
 - Herbalife [384 ITR 276] “Other disbursements”, Citibank NA [377 ITR 69] and host of other decisions restricting application of Sec. 40(a)(i) pre amendment by Finance Act 2003.
 - Many decisions have indeed erroneously referred to Nationality ND provisions instead of Deduction ND provisions.
 - However, each individual DTAA needs to be examined. For e.g. Indian DTAA with Belgium, UK, Italy do not contain Deduction ND clause.
 - Even NR to NR payment covered within scope. [B4U International Holdings Ltd. [2012] 52 SOT 545 (Mumbai)]
- 40(a)(ia) 2nd Proviso: Same conditions as mentioned in Proviso to Sec. 201(1) if satisfied by Non-resident, then 2nd Proviso to Sec. 40(a)(ia) to be read into Sec. 40(a)(i).

Non-Discrimination under ITL

Relevant Indian judicial decisions under Article 24(4) – OECD / UN MC:

- 40(a)(ia): Can limit of non-deduction to 30% for payments to resident be considered as discriminatory? (Similar plea taken in Ciena Communications India (P.) Ltd. [[2018] 98 taxmann.com 458 (Delhi - Trib.)])
- FTC available against Sec. 10A income: Article 24 of the Convention envisages parity of tax liability between the residents of India and Japan. Japan grants tax sparing credit, hence Indian resident can avail FTC against Sec. 10A income. [Blue Star Infotech Ltd. [2015] 57 taxmann.com 386 (Mumbai - Trib.)]. Incorrect decision. Reference to Deduction ND is absurd.



Non-Discrimination under ITL

Article 24(5) – OECD / UN MC:

Enterprises of a Contracting State, the capital of which is wholly or partly owned or controlled, directly or indirectly, by one or more residents of the other Contracting State, shall not be subjected in the first-mentioned State to any **taxation** or **any requirement connected therewith** which is **other** or **more burdensome** than the taxation and connected requirements to which **other similar enterprises** of the firstmentioned State are or may be subjected.

- Group taxation outside the scope since this provision is aimed at payer related ND and not beyond that
- Stringent TP documentation is permissible (Para 80 to Art 24(5) OECD MC Commentary). More burdensome requirement prohibited under Art. 24(5)?

Non-Discrimination under ITL

Relevant Indian judicial decisions under Article 24(5) – OECD / UN MC:

- Sec. 79: [Daimler Chrysler India (P.) Ltd. [2009] 29 SOT 202 (PUNE)]
 - Unless a company in which public is substantially interested, any change in shareholding beyond 51% would disentitle the company to carry forward and set-off the accumulated losses
 - Benefit granted when an Indian subsidiary has an Indian parent company whose shares are listed on any recognized stock exchange of its domicile country, i.e., India, but not granted if it has a German parent company shares of which were listed in any stock exchange in its domiciled country, i.e., Germany.
 - No rational basis for this differentiation in treatment.
 - Therefore, Art. 24(5) overrides Sec. 79 in this case.



Non-Discrimination under ITL

Relevant Indian judicial decisions under Article 24(5) – OECD / UN MC:

- Sec. 195: Pre-1941A, No requirement of TDS u/s 195 since no corresponding provision for TDS when payment made to resident for acquisition of land. [Santur Developers (P.) Ltd. [2015] 61 taxmann.com 304 (Delhi - Trib.)]. Incorrect decision since not related to foreign ownership. Further, no discrimination at all that can be challenged under any ND clause.



Non-Discrimination under ITL

Article 24(6) – OECD / UN MC:

The provisions of this Article shall, notwithstanding the provisions of Article 2, apply to taxes of every kind and description.

- Therefore, ND provisions apply to all kinds of taxes such as indirect taxes as well as state level or municipal level taxes
- But many Indian DTAA's restrict the scope of taxation to taxes covered within Art. 2 of the convention.



Non-Discrimination under ITL

Case Studies:

1. Equalisation levy – Chapter VIII of Finance Act 2016, Sec. 40(a)(ib), Sec. 10(50)
2. Secondary Adjustment – Sec. 92CE
3. Interest deduction limitation (not same as thin capitalisation) – Sec. 94B
4. FCo1 indirectly holds 100% shares in IndCo through FCo2. FCo2 wants to sell shares in IndCo to FCo1. Can FCo2 claim discrimination of provisions u/s 47(v)?



Thank you



Disclaimer : The opinions and views expressed in this presentation are for informational purposes only. The information is not intended to be a substitute for professional opinion. A fact-based professional opinion should always be sought before advising the client.



Contact Information

Harshal Bhuta

M.Com., F.C.A., A.D.I.T., LL.M. (Hons.) in Intl. Tax Law [Wirtschaftsuniversität Wien]



Address 2-I, Jeevan Sahakar, 2nd Floor, Sir P. M. Road, Fort, Mumbai – 400001, India.

Telephone +91 22 22660010/3427 ; 43471727

Mobile +91 9930114418

Fax +91 22 22662793

E-mail harshal.bhuta@bhutaco.com

Website www.bhutaco.com